

## 106C Concealed Fix Gravity Hinge

### Material Specifications

- Diecast Zinc, Alloy ZP3
- #304 Stainless Steel Shaft
- Nylon Inserts
- ABS Snap On Covers

### Mounting

- Surface Mounted Concealed Screw Fix
- Bolt Through Set Up

### Dimensions

- 85mm W (with ABS snap on covers) x 83mm H x 16mm D

### Finish

- 106C\_SCP: Satin Chrome Plate
- 106C\_Designer: Designer Black
- 106C\_ANMB: Antimicrobial Coating
- 106C\_SNP: Satin Nickel Plate
- 106C\_SPP: Satin Pearl Plate

**Features:** Lift off capability

### Installation Guidelines

1. May be subject to Australian Building Code Regulations or architectural drawings for height placement, which is the responsibility of the installer. It is recommended that each pair of hinges (two) carry no more than 30kg in load for effective operational longevity. For doors over 30kgs allow an additional hinge per 15kg.
2. Measure and locate hinge fixture heights on rear of frontal. Position leaf without pin along the inner rear edge of the frontal. Mark and pre-drill rear of frontal for fixing, then secure hinges with appropriate fasteners. Then screw loose leaf hinge to door.
3. NOTE: If using a screw fix set up ensure the screws are no greater than 90% in length of the material thickness where the hinge is being affixed. If using a Bolt through set up, ensure the all thread ordered exceeds material thickness by at least 7mm either side for securing of the dome nuts/ washers. An alternate Bolt Through set up is to use the *Metlam 106C Concealed Fix Faceplate* (refer to website for further details). Recommendation is to use the Loctite® or similar on Bolt Through Fixings.
4. Locate/Hang door onto pre-fixed hinges at rear of frontal. Check action for smooth uninterrupted opening/closing.

**NOTE:** Other Hardware (such as the indicator set or hook(s) can be pre-fitted or retro fitted as required.



\*106C\_SCP



\*106C\_Designer



\*106C\_ANMB

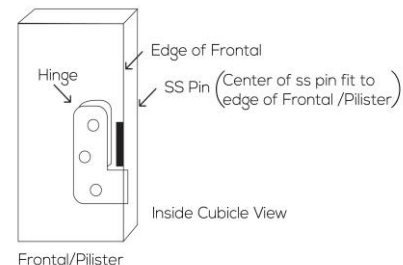
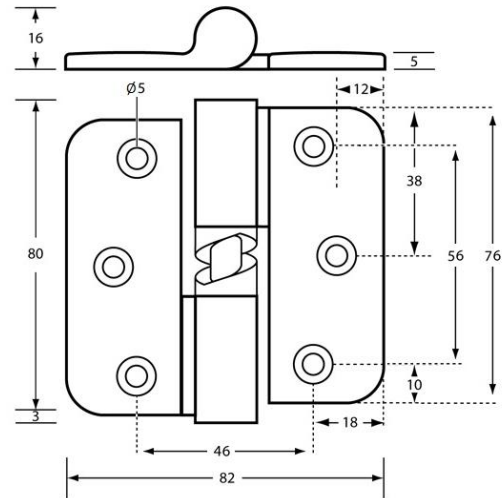

The photographs and line drawings of the products presented above are representational only. Metlam Australia Pty Ltd reserves the right to, and from time to time, make changes and improvements in design and dimensions.

# Installation Guidelines Sheet



---

*The technical recommendations contained in this document are necessarily of a general nature and should not be relied on for specific applications without first securing competent advice. Whilst Metlam Australia Pty Ltd has taken all reasonable steps to ensure the information contained herein is accurate and current, it does not warrant the accuracy or completeness of the information and does not accept liability for errors or omissions. Any Commercial product should only be installed by a competent tradesperson and serviced/maintained by knowledgeable janitorial staff or competent people. Metlam Australia accepts no responsibility for any damage to product, walls or fixtures due to incorrect installation or maintenance of any of their products.*

The photographs and line drawings of the products presented above are representational only.  
Metlam Australia Pty Ltd reserves the right to, and from time to time, make changes and improvements in design and dimensions.